

Acoustic 360 bass fuzz

©2013 moosapotamus

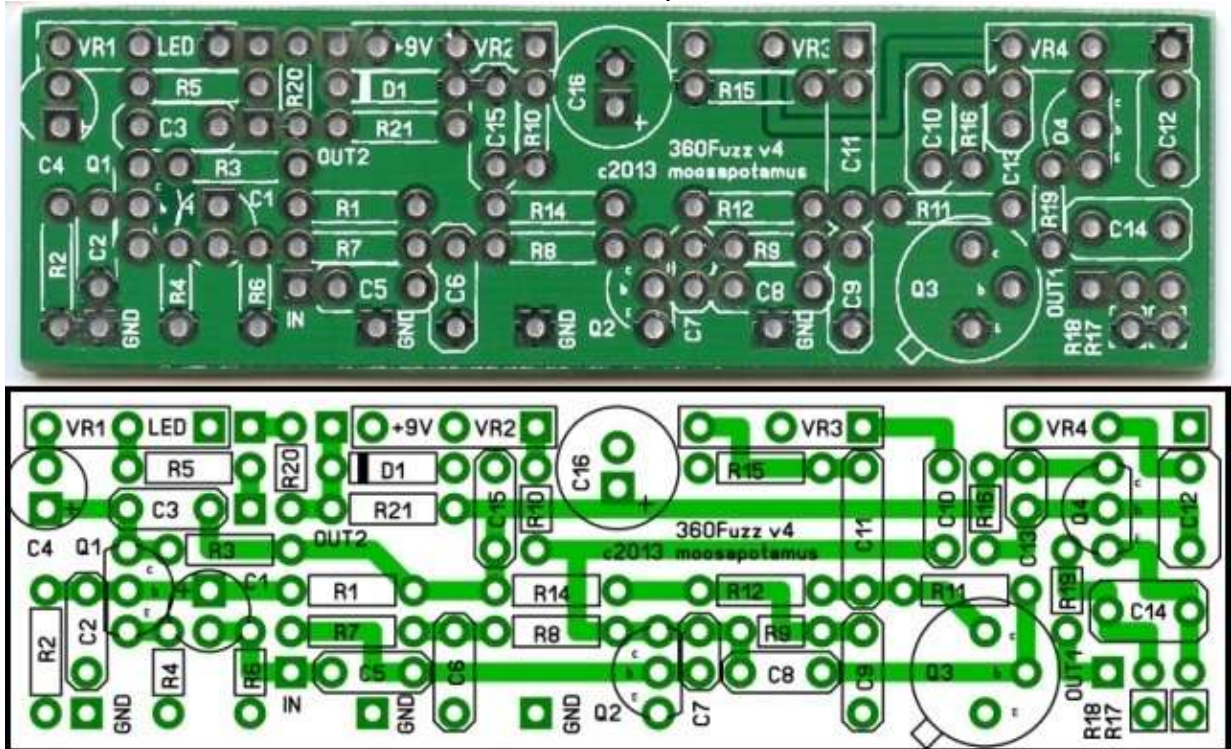

DESCRIPTION:

This is the fuzz circuit from the classic Acoustic 360 Bass preamplifier, with some modifications enabling a greater range of sounds than the original as well as optimization for 9VDC operation. The circuit can also be powered with up to 18VDC, for slightly more “extreme” sounding fuzz.

FEATURES:

- Clean blend control based on vintage style clean bass boost circuit.
- Decay control for gated synth-like fuzz sounds.
- Option to add a second clean bass output.
- Original Fuzz (gain) and Attack controls retained to achieve stock 360 fuzz sounds.

NOTES:

If you plan to wire in the second, clean output, use a mono switching jack (ie. Switchcraft 502-12A). With nothing plugged into Out2, you’ll have both fuzz and clean signals mixed at Out1. Plugging another jack into Out2 takes the clean signal away from Out1, leaving only fuzz at Out1, and provides the clean signal at Out2. In either case, the fuzz and clean levels are always set with the Fuzz and Clean controls, respectively. Second output not shown on schematic. See wiring diagram, below.

There is some DC voltage on the Decay pot, so it makes a soft scratchy noise only when it’s adjusted. But I really like the gated fuzz sounds you can get from it. So I think it’s worth it. If you don’t like it, you don’t have to install VR2 and R10.

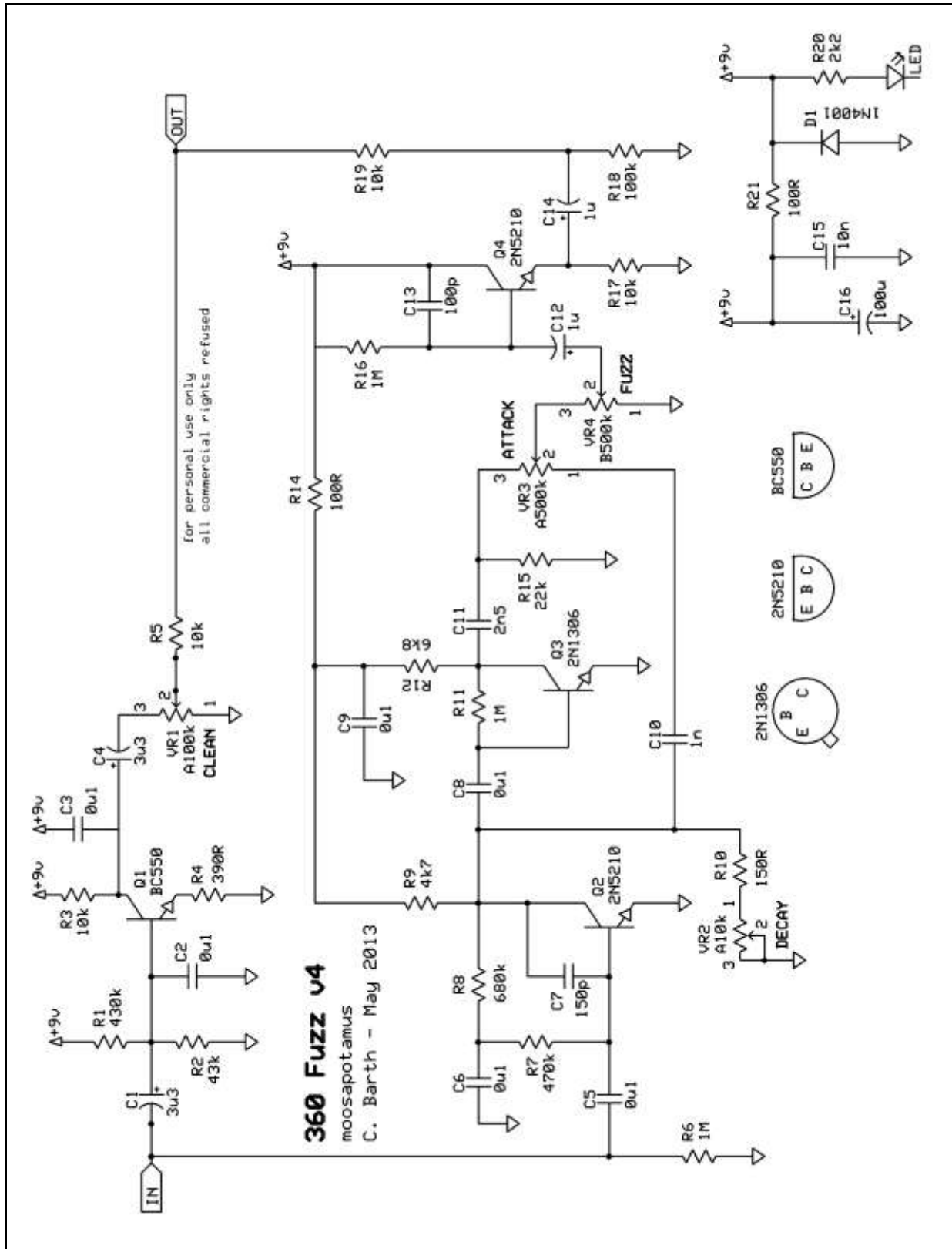

BILL OF MATERIALS

ref	Value		ref	value		qty	value	ref
R1	430k		C1	3u3		1	100p	C13
R2	43k		C2	0u1		1	150p	C7
R3	10k		C3	0u1		1	1n	C10
R4	390R		C4	3u3		1	2n5	C11
R5	10k		C5	0u1		1	10n	C15
R6	1M		C6	0u1		6	0u1	C2, C3, C5, C6, C8, C9
R7	470k		C7	150p		2	1u	C12, C14
R8	680k		C8	0u1		2	3u3	C1, C4
R9	4k7		C9	0u1		1	100u	C16
R10	150R		C10	1n				
R11	1M		C11	2n5		1	1N4001	D1
R12	6k8		C12	1u		1	LED	LED
R14	100R		C13	100p		1	BC550	Q1
R15	22k		C14	1u		2	2N5210	Q2, Q4
R16	1M		C15	10n		1	2N1306	Q3
R17	10k		C16	100u				
R18	100k		D1	1N4001		2	100R	R14, R21
R19	10k		LED			1	150R	R10
R20	2k2		Q1	BC550		1	390R	R4
R21	100R		Q2	2N5210		1	2k2	R20
VR1	A100k		Q3	2N1306		1	4k7	R9
VR2	A10k		Q4	2N5210		1	6k8	R12
VR3	A500k					4	10k	R3, R5, R17, R19
VR4	B500k					1	22k	R15
						1	43k	R2
						1	100k	R18
						1	430k	R1
						1	470k	R7
						1	680k	R8
						3	1M	R6, R11, R16
						1	A100k	VR1
						1	A10k	VR2
						1	A500k	VR3
						1	B500k	VR4
Also: stomp switch, enclosure, jacks, LED bezel, battery snap, etc...								

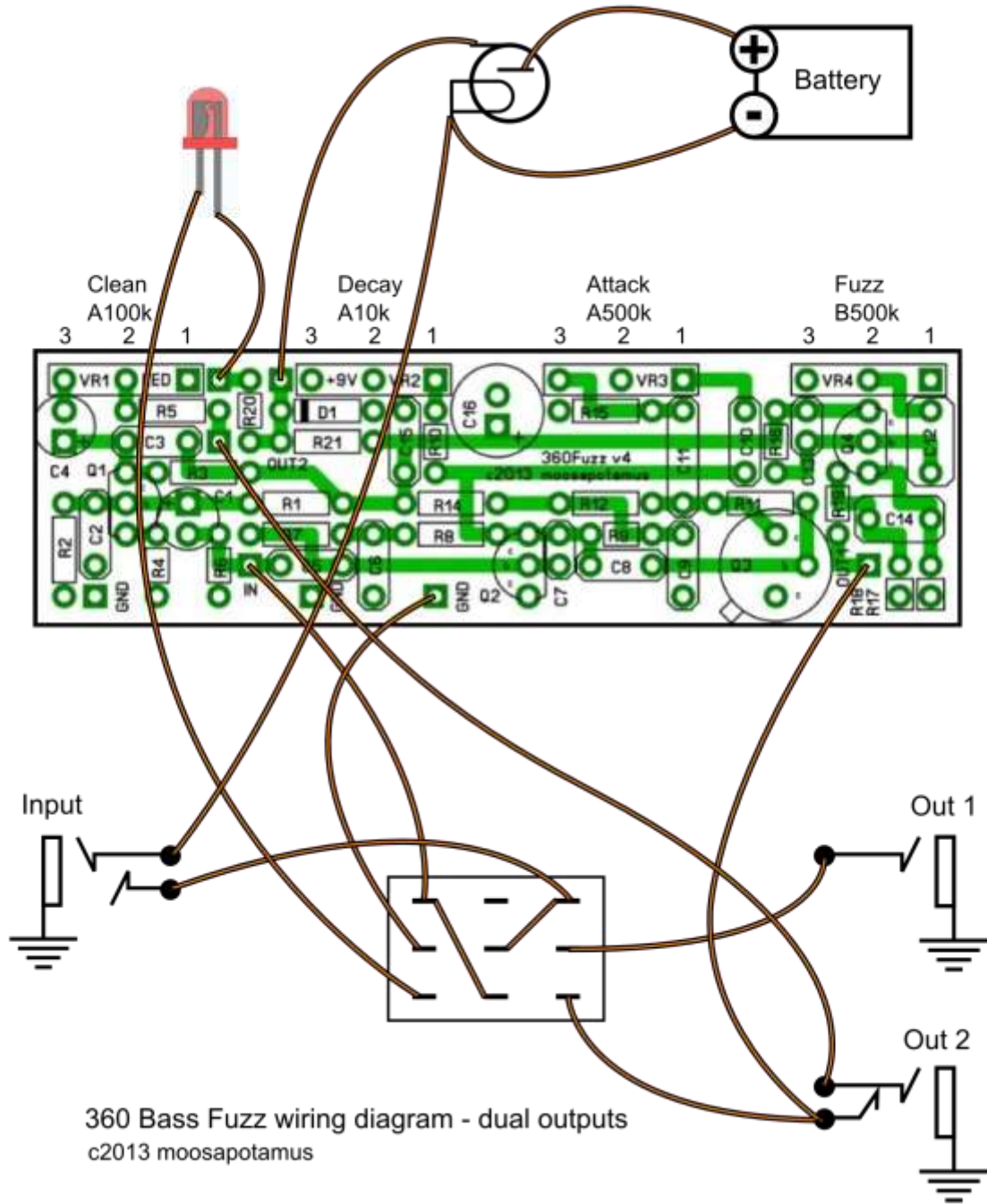

360 Bass Fuzz wiring diagram - dual outputs
©2013 moosapotamus

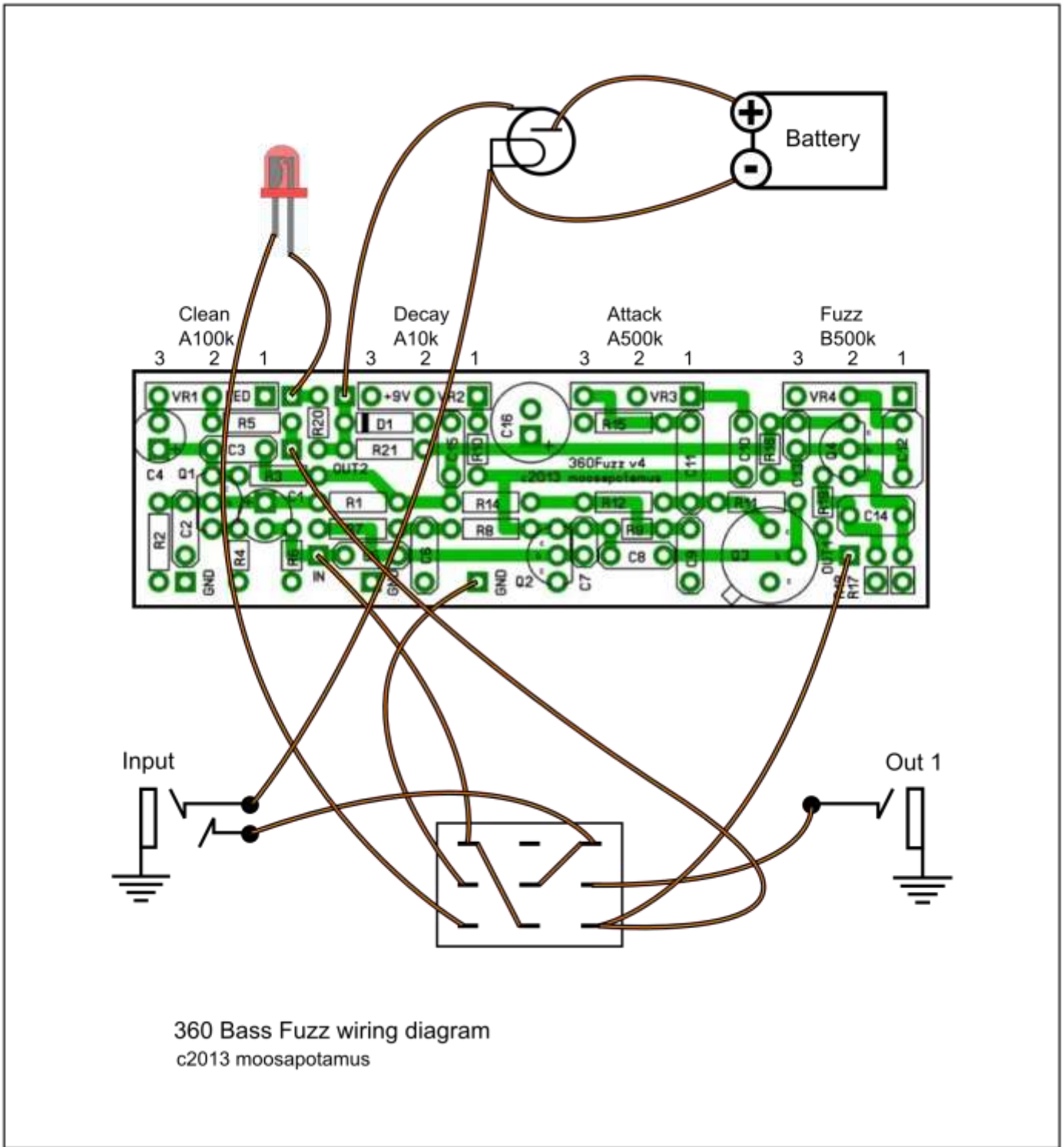

Sound clips available at: <http://soundcloud.com/moosapotamus>

Video demos available at: <http://www.youtube.com/user/moosapotamus>



Given the small size of the circuit board, you could obviously build this into a much smaller enclosure, if you like. Also note, I added a battery snap as a convenience in the above build. But this circuit actually doesn't seem to perform very well once the battery starts to die a little. Long term, it's much better to just use an external power supply.

Single-sided Layout

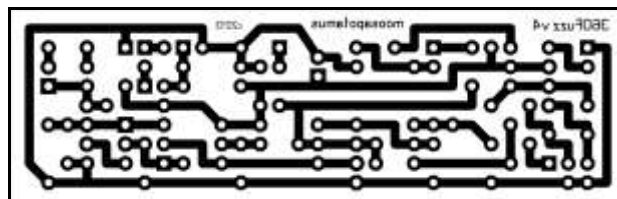
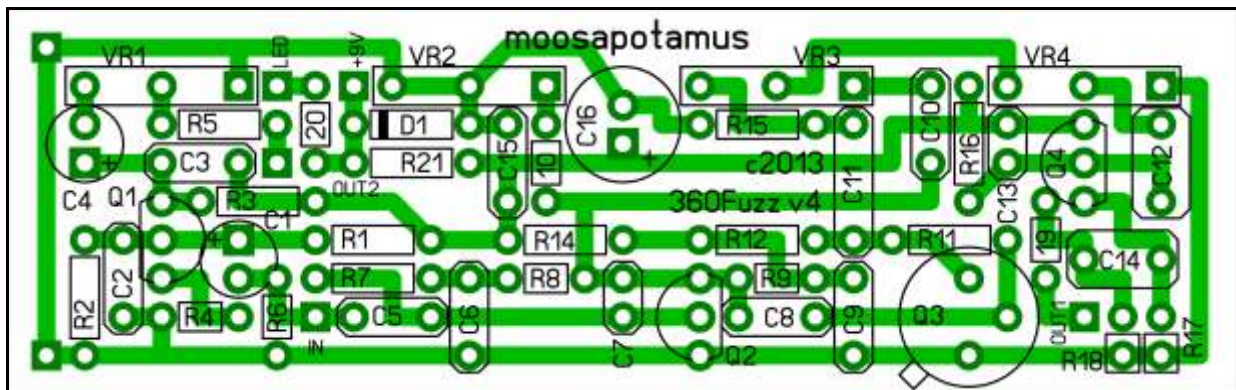

1.0" x 3.2"